

PROFILE DIMENSION GUIDE



Muskoka Timber Mills

(705) 645-5755

info@muskokatimbermills.com

2152 Manitoba St, Bracebridge ON, P1L 1X5



WOOD SIDING THAT LASTS A LIFETIME

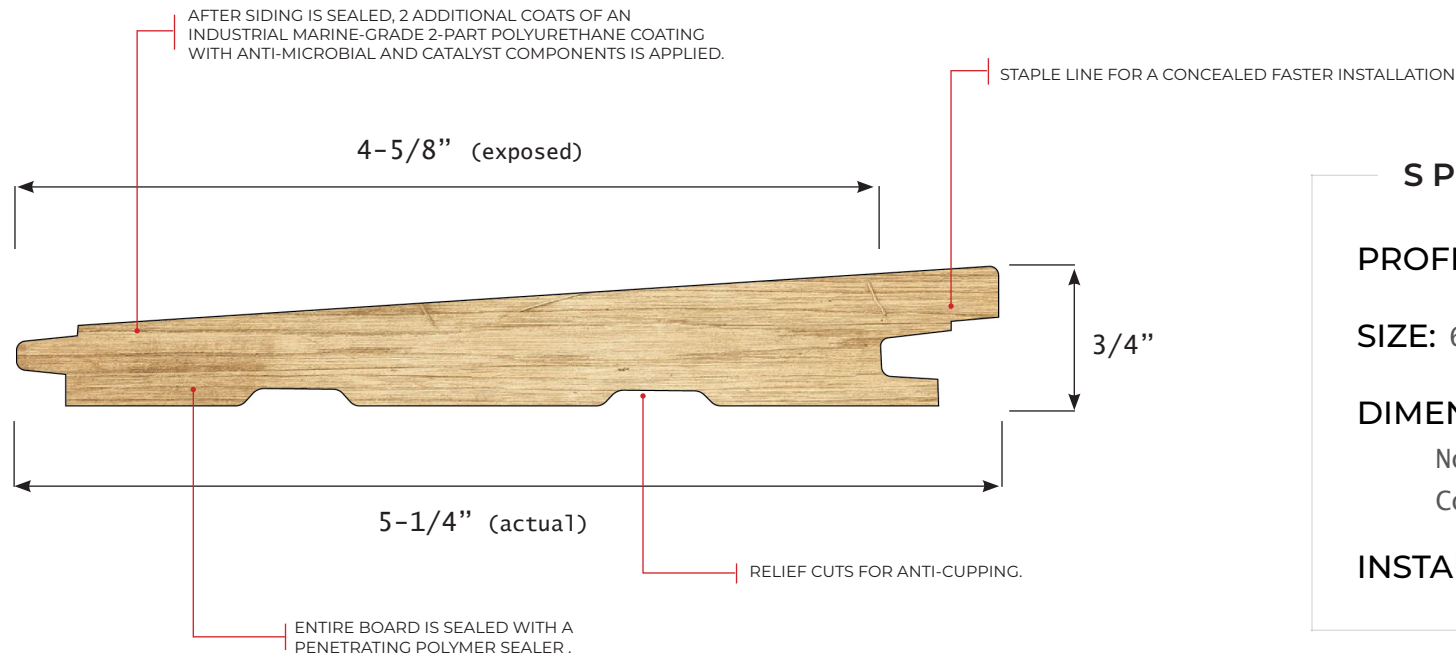

SPECIFICATIONS

PROFILE: BEVEL

SIZE: 6" Profile

DIMENSIONS:

Nominal: 3/4" x 5-1/4"

Coverage: 4-5/8"

INSTALL: Horizontal

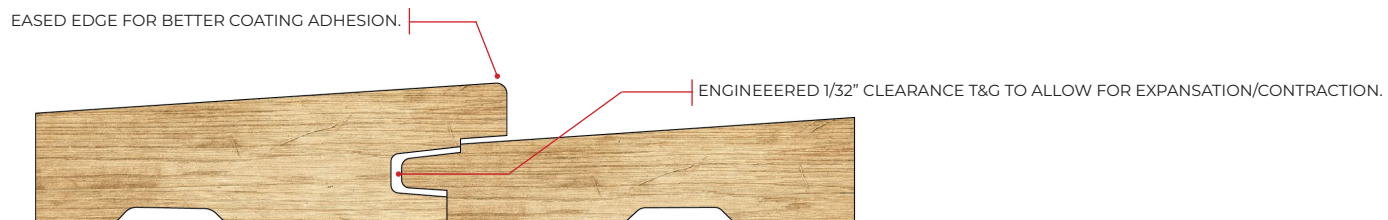

- WATERPROOF 2-PART POLYURETHANE COATING
- TONGUE & GROOVE FOR SEAMLESS DESIGN

- END-MATCHED FOR CLEAN TRANSITIONS
- STANDARD RESAWN FINISH

- CUSTOM COLOUR MATCHING
- KILN-DRIED WHITE PINE



WOOD SIDING THAT LASTS A LIFETIME



AFTER SIDING IS SEALED, 2 ADDITIONAL COATS OF AN INDUSTRIAL MARINE-GRADE 2-PART POLYURETHANE COATING WITH ANTI-MICROBIAL AND CATALYST COMPONENTS IS APPLIED.

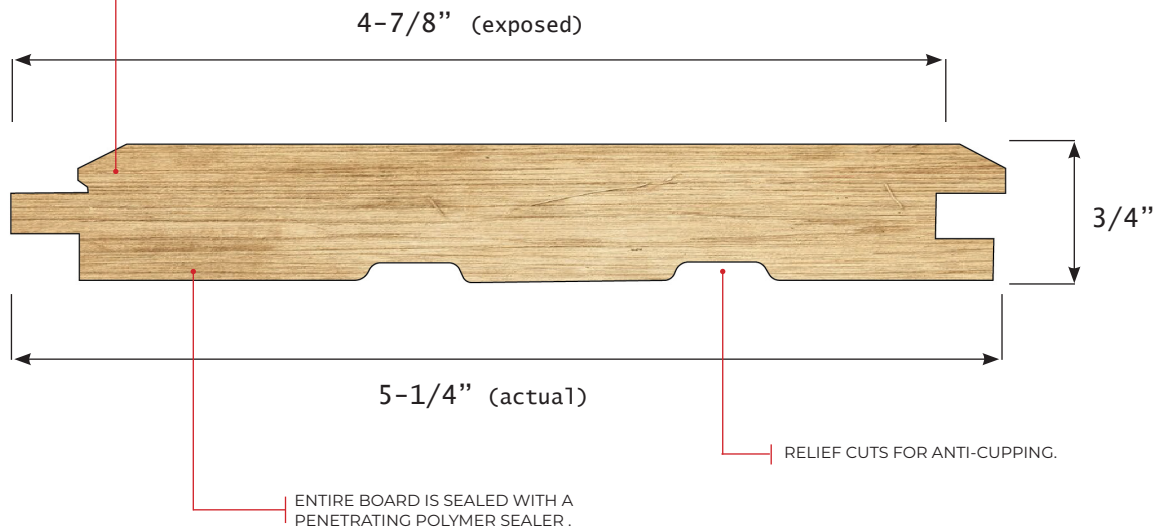

SPECIFICATIONS

PROFILE: V-JOINT

SIZE: 6" Profile

DIMENSIONS:

Nominal: 3/4" x 5-1/4"

Coverage: 4-7/8"

INSTALL: Horizontal or Vertical



- WATERPROOF 2-PART POLYURETHANE COATING
- TONGUE & GROOVE FOR SEAMLESS DESIGN

- END-MATCHED FOR CLEAN TRANSITIONS
- STANDARD RESAWN OR WIRE BRUSH FINISH

- CUSTOM COLOUR MATCHING
- KILN-DRIED WHITE PINE



WOOD SIDING THAT LASTS A LIFETIME

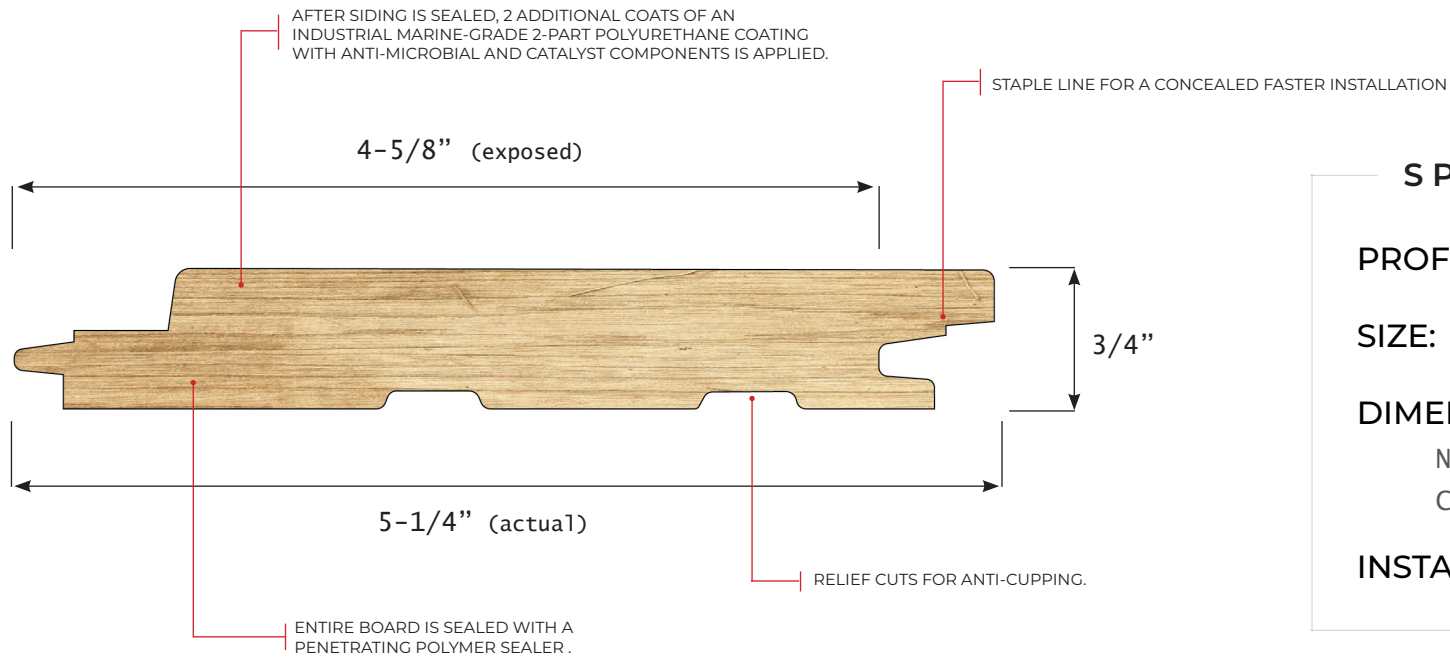

SPECIFICATIONS

PROFILE: SHADOWLINE - TAPERED

SIZE: 6" Profile

DIMENSIONS:

Nominal: 3/4" x 5-1/4"

Coverage: 4-5/8"

INSTALL: Horizontal or Vertical

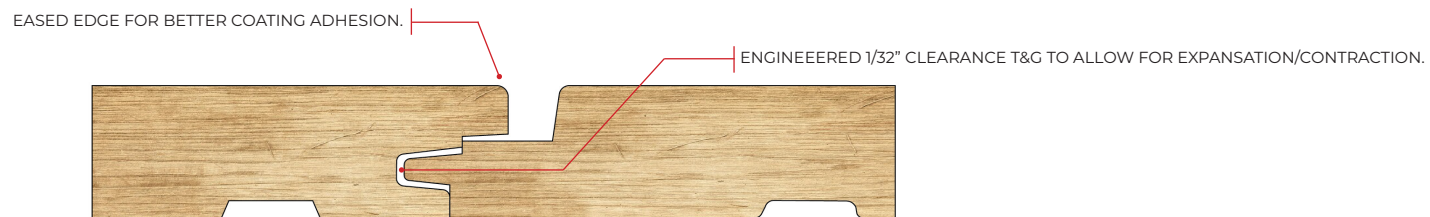

- WATERPROOF 2-PART POLYURETHANE COATING
- TONGUE & GROOVE FOR SEAMLESS DESIGN

- END-MATCHED FOR CLEAN TRANSITIONS
- STANDARD RESAWN OR WIRE BRUSH FINISH

- CUSTOM COLOUR MATCHING
- KILN-DRIED WHITE PINE



WOOD SIDING THAT LASTS A LIFETIME

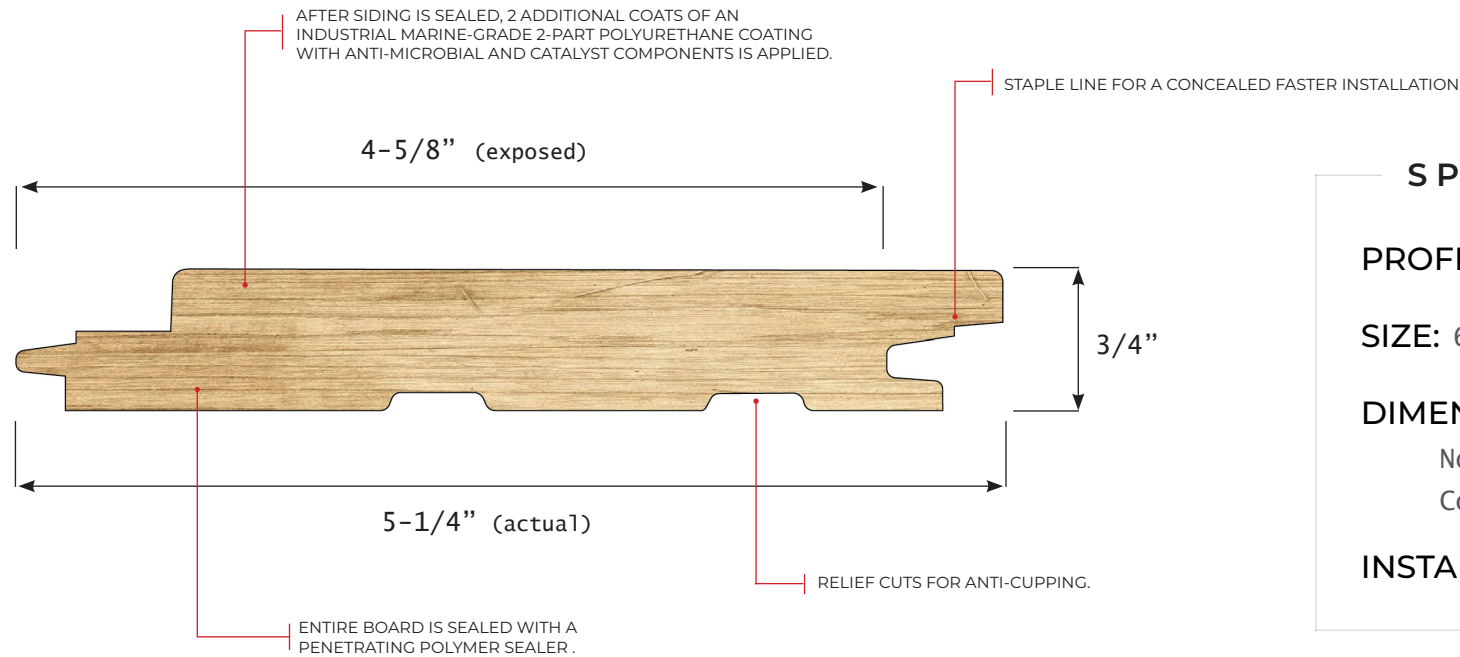

SPECIFICATIONS

PROFILE: SHADOWLINE - SQUARE EDGE
* CUSTOM RUN PROFILE

SIZE: 6" Profile

DIMENSIONS:

Nominal: 3/4" x 5-1/4"

Coverage: 4-5/8"

INSTALL: Vertical

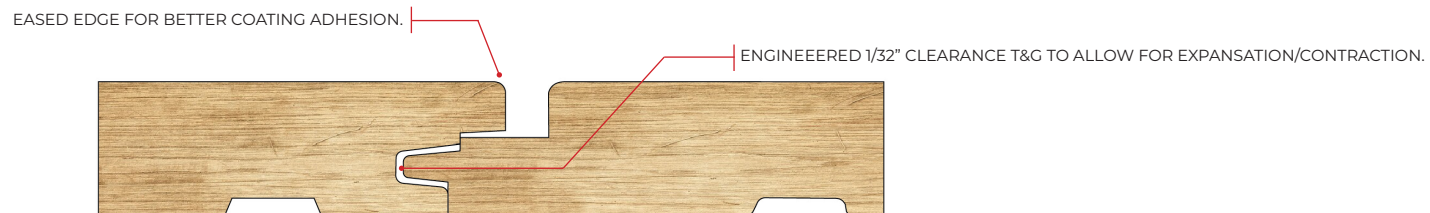

- WATERPROOF 2-PART POLYURETHANE COATING
- TONGUE & GROOVE FOR SEAMLESS DESIGN

- END-MATCHED FOR CLEAN TRANSITIONS
- STANDARD RESAWN OR WIRE BRUSH FINISH

- CUSTOM COLOUR MATCHING
- KILN-DRIED WHITE PINE



WOOD SIDING THAT LASTS A LIFETIME

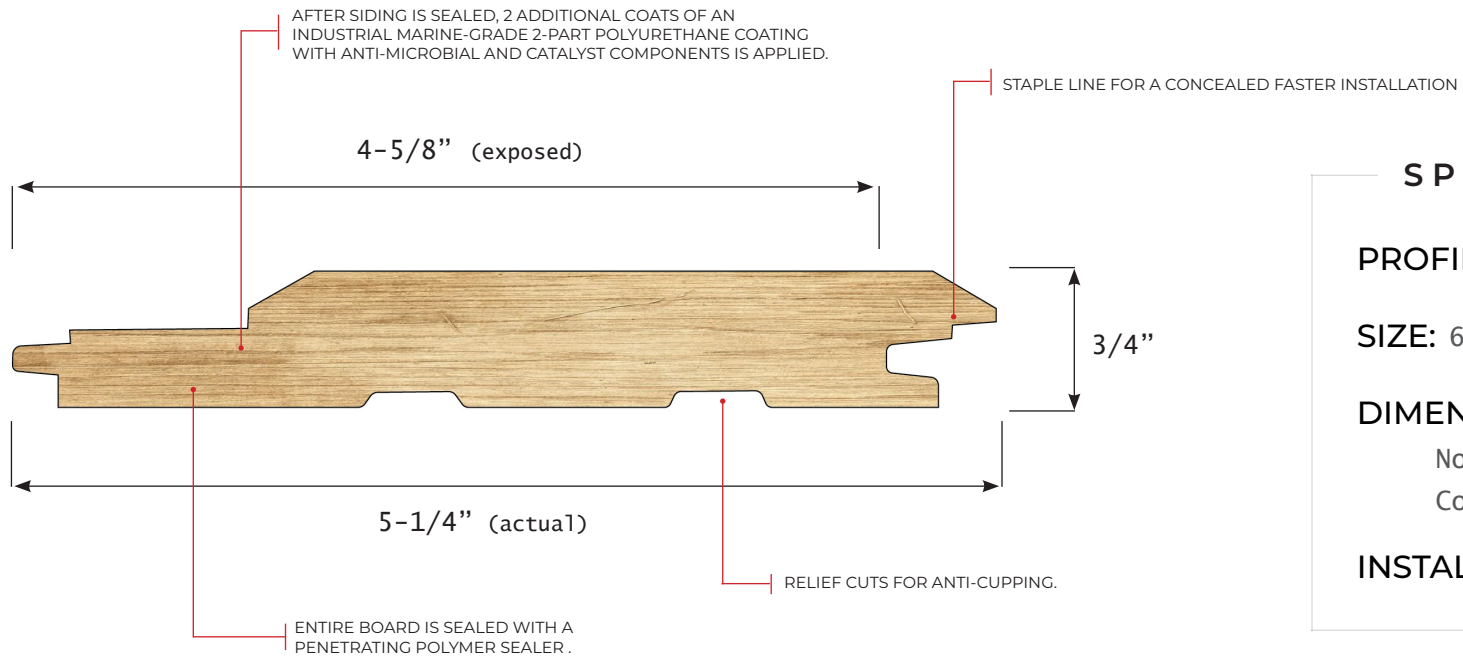

SPECIFICATIONS

PROFILE: CHANNEL
* CUSTOM RUN PROFILE

SIZE: 6" Profile

DIMENSIONS:

Nominal: 3/4" x 5-1/4"

Coverage: 4-5/8"

INSTALL: Horizontal or Vertical

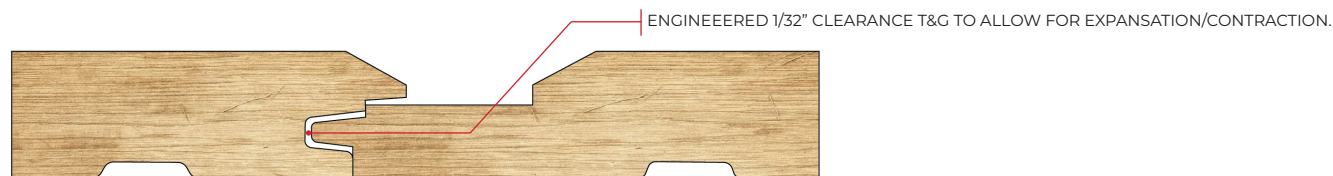

- WATERPROOF 2-PART POLYURETHANE COATING
- TONGUE & GROOVE FOR SEAMLESS DESIGN

- END-MATCHED FOR CLEAN TRANSITIONS
- STANDARD RESAWN OR WIRE BRUSH FINISH

- CUSTOM COLOUR MATCHING
- KILN-DRIED WHITE PINE



WOOD SIDING THAT LASTS A LIFETIME

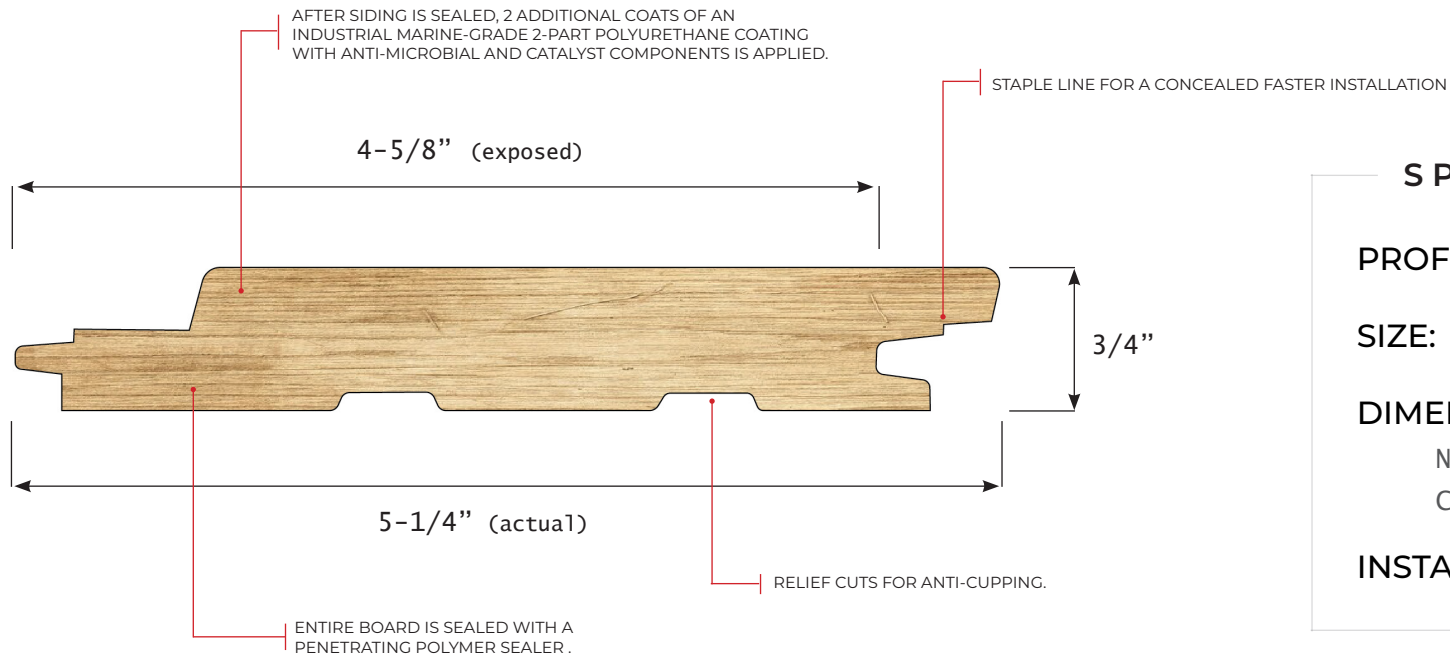

SPECIFICATIONS

PROFILE: EURO CHANNEL
* CUSTOM RUN PROFILE

SIZE: 6" Profile

DIMENSIONS:

Nominal: 3/4" x 5-1/4"

Coverage: 4-5/8"

INSTALL: Horizontal or Vertical

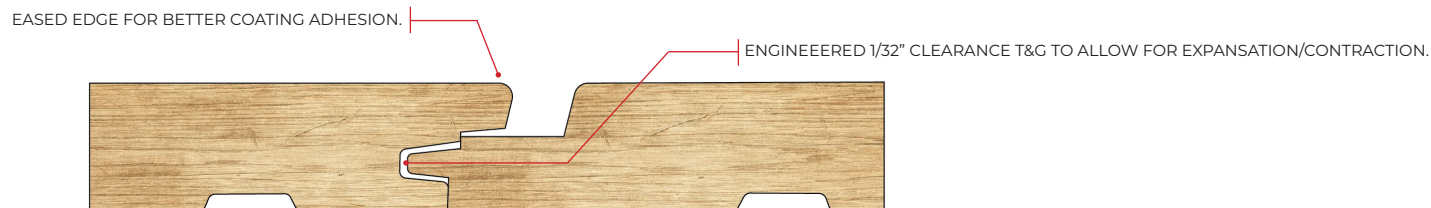

- WATERPROOF 2-PART POLYURETHANE COATING
- TONGUE & GROOVE FOR SEAMLESS DESIGN

- END-MATCHED FOR CLEAN TRANSITIONS
- STANDARD RESAWN OR WIRE BRUSH FINISH

- CUSTOM COLOUR MATCHING
- KILN-DRIED WHITE PINE



WOOD SIDING THAT LASTS A LIFETIME

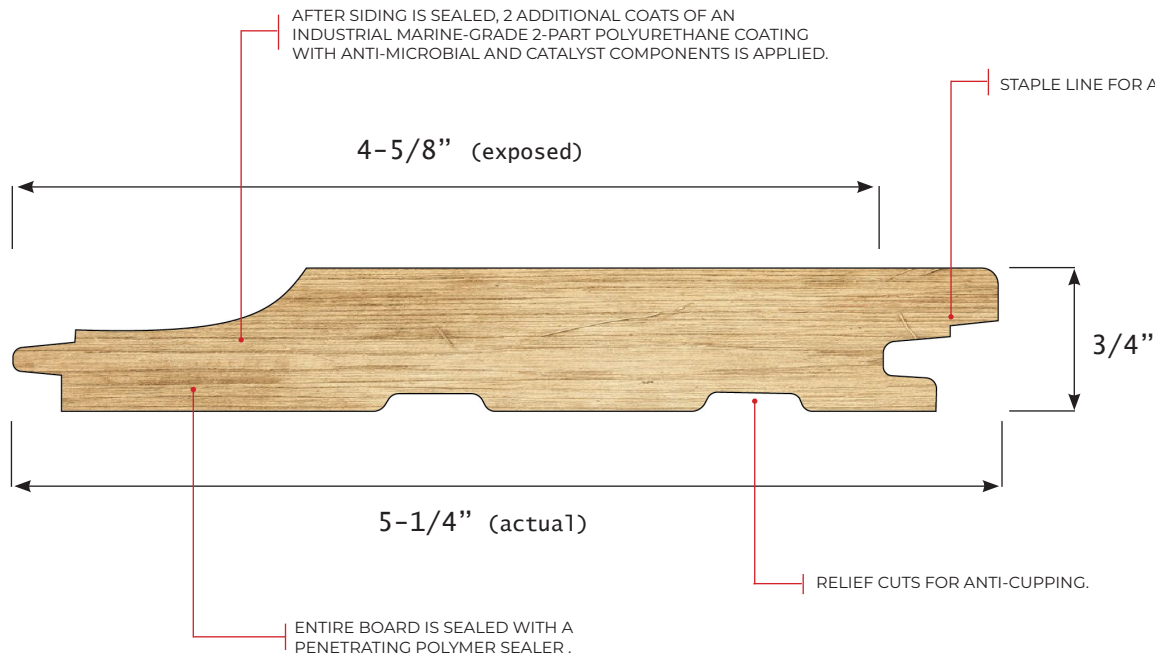

SPECIFICATIONS

PROFILE: COVE
* CUSTOM RUN PROFILE

SIZE: 6" Profile

DIMENSIONS:
Nominal: 3/4" x 5-1/4"
Coverage: 4-5/8"

INSTALL: Horizontal

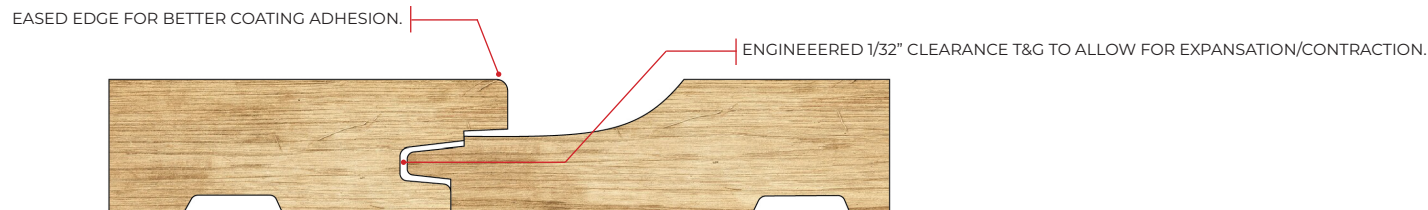

- WATERPROOF 2-PART POLYURETHANE COATING
- END-MATCHED FOR CLEAN TRANSITIONS
- CUSTOM COLOUR MATCHING
- TONGUE & GROOVE FOR SEAMLESS DESIGN
- STANDARD RESAWN OR WIRE BRUSH FINISH
- KILN-DRIED WHITE PINE



WOOD SIDING THAT LASTS A LIFETIME



AFTER SIDING IS SEALED, 2 ADDITIONAL COATS OF AN INDUSTRIAL MARINE-GRADE 2-PART POLYURETHANE COATING WITH ANTI-MICROBIAL AND CATALYST COMPONENTS IS APPLIED.

STAPLE LINE FOR A CONCEALED FASTER INSTALLATION

6-5/8" (exposed)

3/4"

7-1/4" (actual)

RELIEF CUTS FOR ANTI-CUPPING.

ENTIRE BOARD IS SEALED WITH A PENETRATING POLYMER SEALER.

SPECIFICATIONS

PROFILE: BEVEL

SIZE: 8" Profile

DIMENSIONS:

Nominal: 3/4" x 7-1/4"

Coverage: 6-5/8"

INSTALL: Horizontal

EASED EDGE FOR BETTER COATING ADHESION.

ENGINEERED 1/32" CLEARANCE T&G TO ALLOW FOR EXPANSION/CONTRACTION.



- WATERPROOF 2-PART POLYURETHANE COATING
- TONGUE & GROOVE FOR SEAMLESS DESIGN

- END-MATCHED FOR CLEAN TRANSITIONS
- STANDARD RESAWN FINISH

- CUSTOM COLOUR MATCHING
- KILN-DRIED WHITE PINE



WOOD SIDING THAT LASTS A LIFETIME

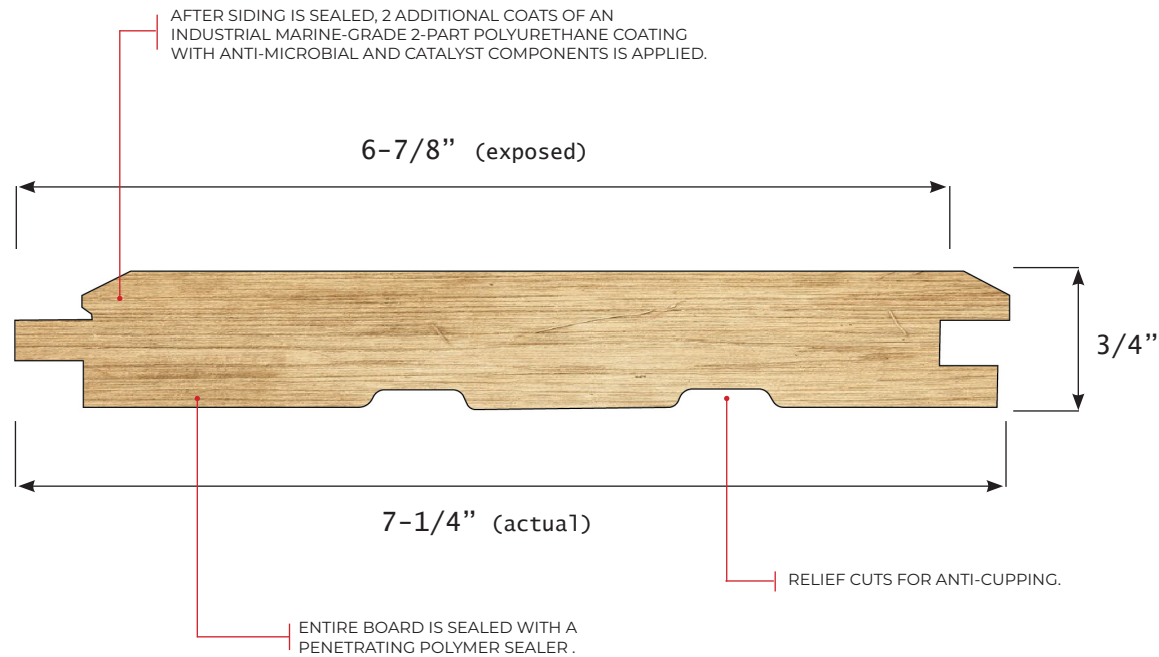

SPECIFICATIONS

PROFILE: V-JOINT

SIZE: 8" Profile

DIMENSIONS:

Nominal: 3/4" x 7-1/4"

Coverage: 6-7/8"

INSTALL: Horizontal or Vertical

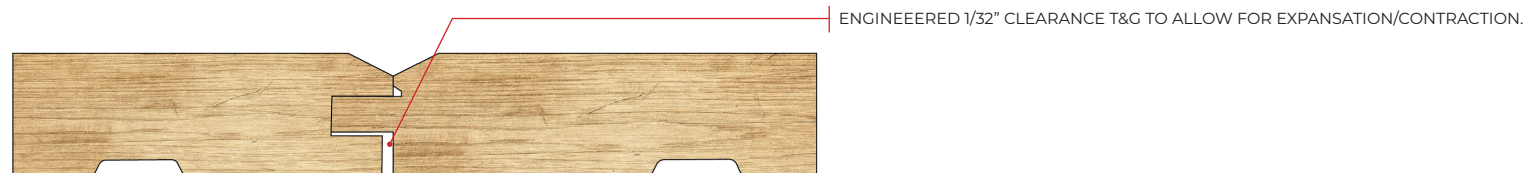

- WATERPROOF 2-PART POLYURETHANE COATING
- TONGUE & GROOVE FOR SEAMLESS DESIGN

- END-MATCHED FOR CLEAN TRANSITIONS
- STANDARD RESAWN OR WIRE BRUSH FINISH

- CUSTOM COLOUR MATCHING
- KILN-DRIED WHITE PINE



WOOD SIDING THAT LASTS A LIFETIME

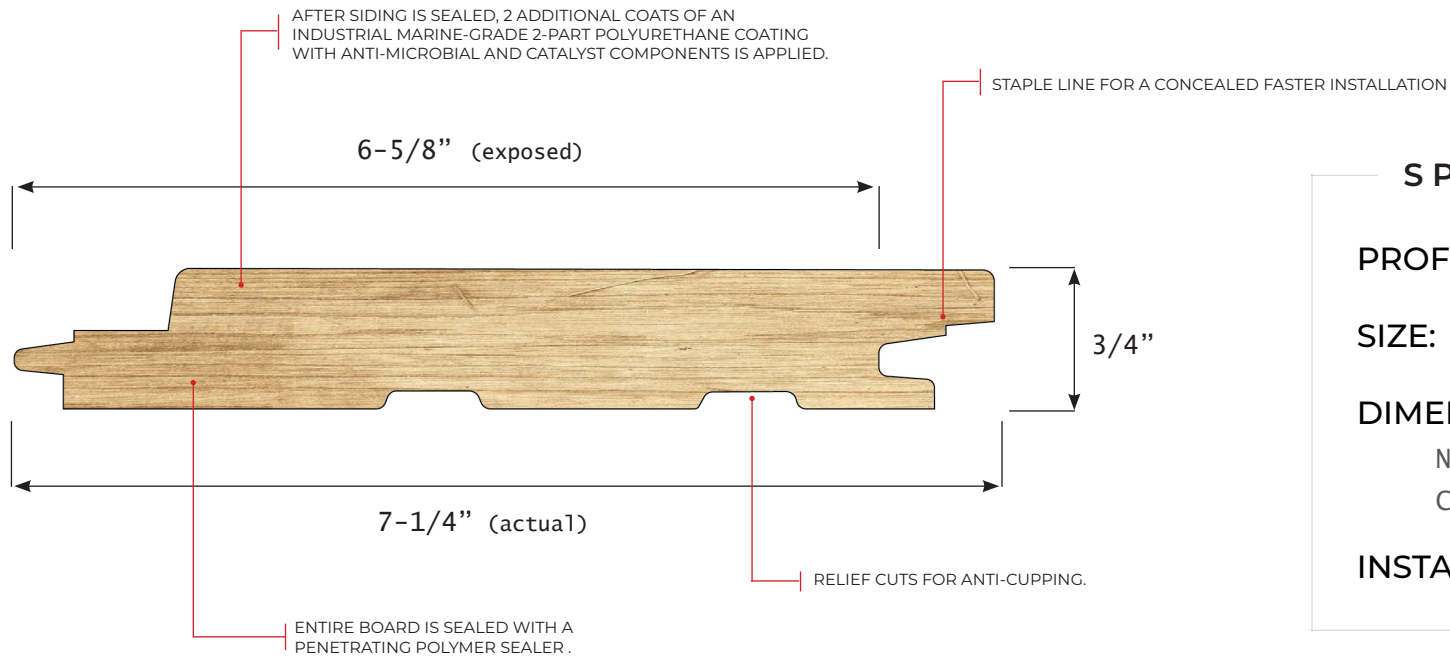

SPECIFICATIONS

PROFILE: SHADOWLINE - TAPERED

SIZE: 8" Profile

DIMENSIONS:

Nominal: 3/4" x 7-1/4"

Coverage: 6-5/8"

INSTALL: Horizontal or Vertical

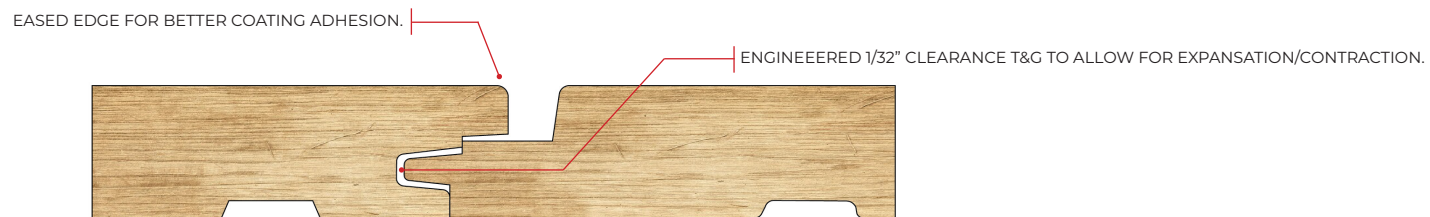

- WATERPROOF 2-PART POLYURETHANE COATING
- TONGUE & GROOVE FOR SEAMLESS DESIGN

- END-MATCHED FOR CLEAN TRANSITIONS
- STANDARD RESAWN OR WIRE BRUSH FINISH

- CUSTOM COLOUR MATCHING
- KILN-DRIED WHITE PINE



WOOD SIDING THAT LASTS A LIFETIME

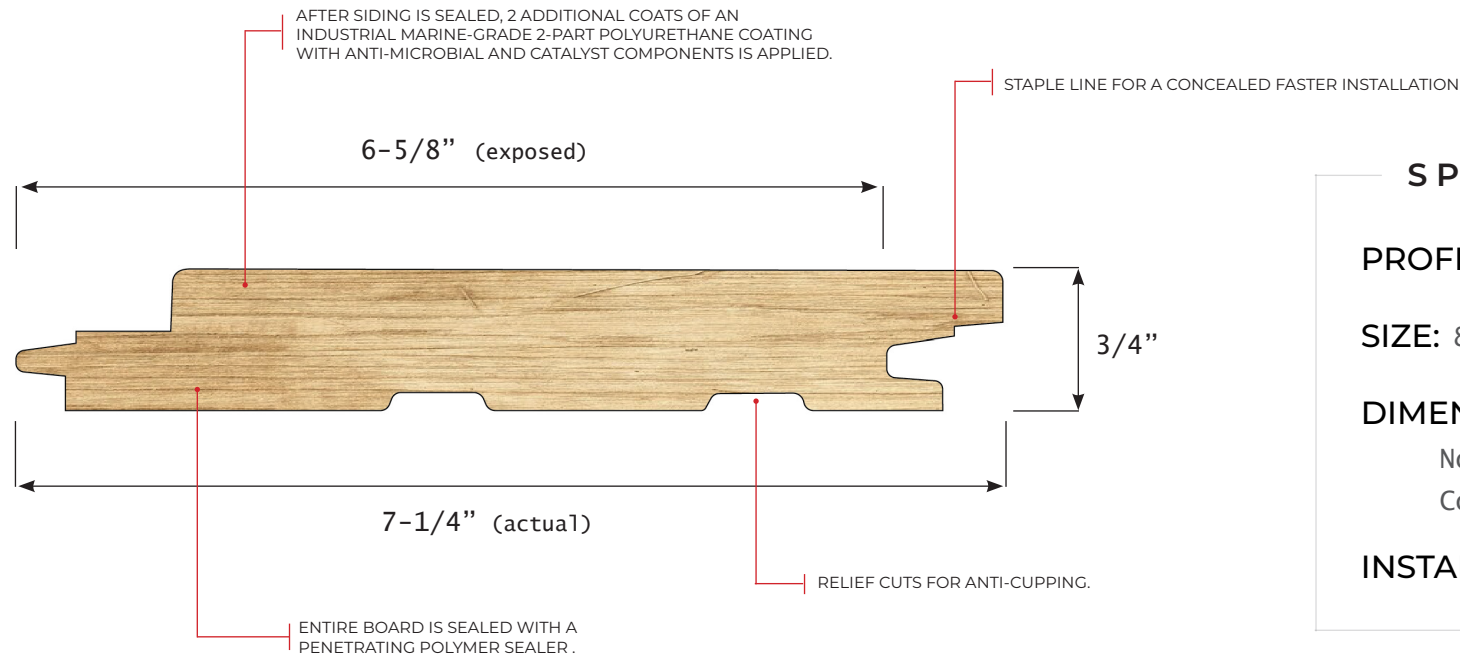

SPECIFICATIONS

PROFILE: SHADOWLINE - SQUARE EDGE
* CUSTOM RUN PROFILE

SIZE: 8" Profile

DIMENSIONS:

Nominal: 3/4" x 7-1/4"

Coverage: 6-5/8"

INSTALL: Horizontal or Vertical

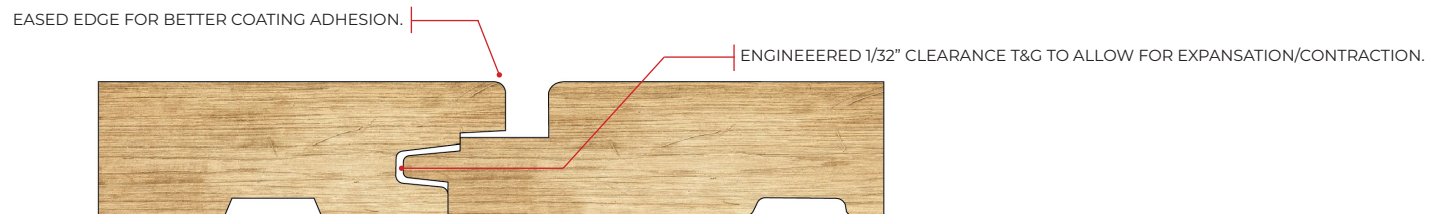

- WATERPROOF 2-PART POLYURETHANE COATING
- TONGUE & GROOVE FOR SEAMLESS DESIGN

- END-MATCHED FOR CLEAN TRANSITIONS
- STANDARD RESAWN OR WIRE BRUSH FINISH

- CUSTOM COLOUR MATCHING
- KILN-DRIED WHITE PINE



WOOD SIDING THAT LASTS A LIFETIME

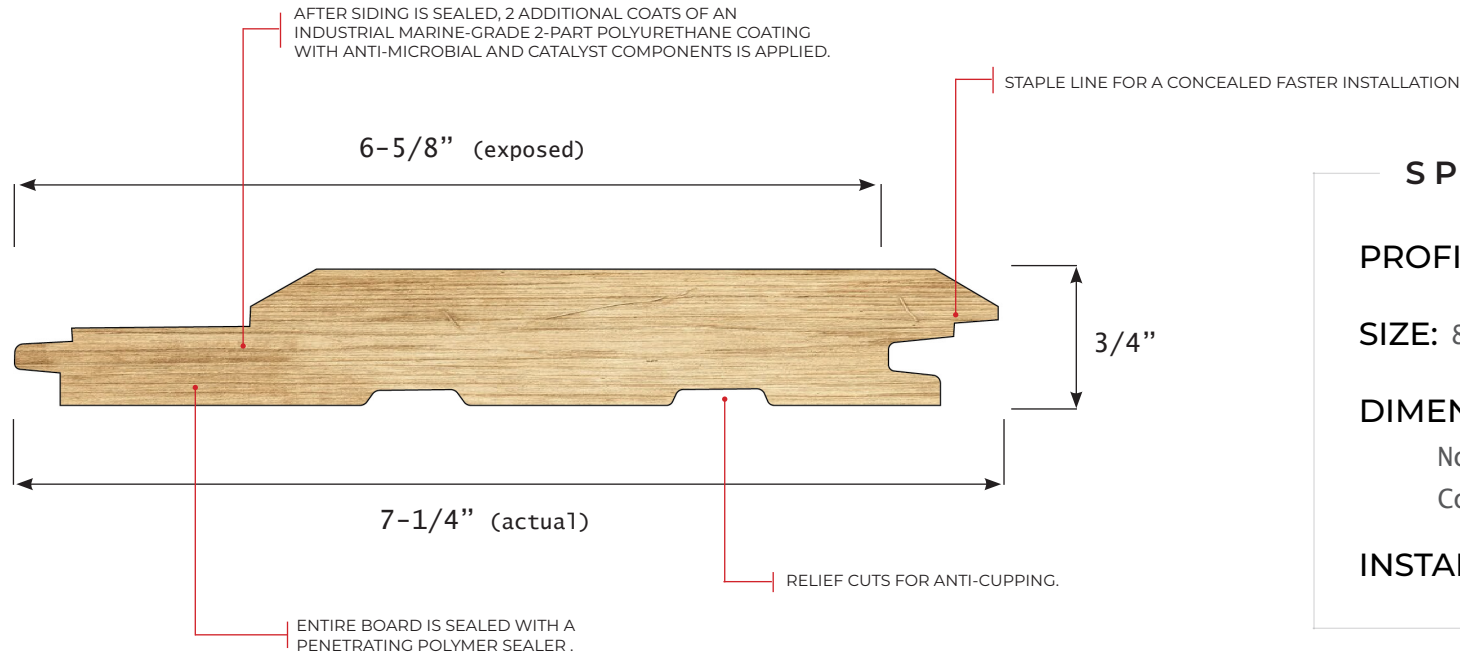

SPECIFICATIONS

PROFILE: CHANNEL
* CUSTOM RUN PROFILE

SIZE: 8" Profile

DIMENSIONS:

Nominal: 3/4" x 7-1/4"

Coverage: 6-5/8"

INSTALL: Horizontal or Vertical

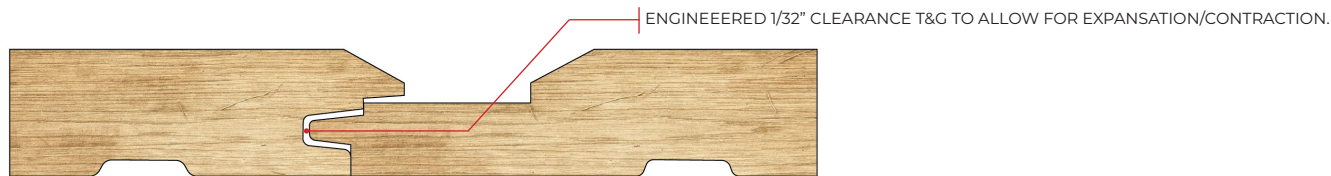

- WATERPROOF 2-PART POLYURETHANE COATING
- TONGUE & GROOVE FOR SEAMLESS DESIGN

- END-MATCHED FOR CLEAN TRANSITIONS
- STANDARD RESAWN OR WIRE BRUSH FINISH

- CUSTOM COLOUR MATCHING
- KILN-DRIED WHITE PINE



WOOD SIDING THAT LASTS A LIFETIME

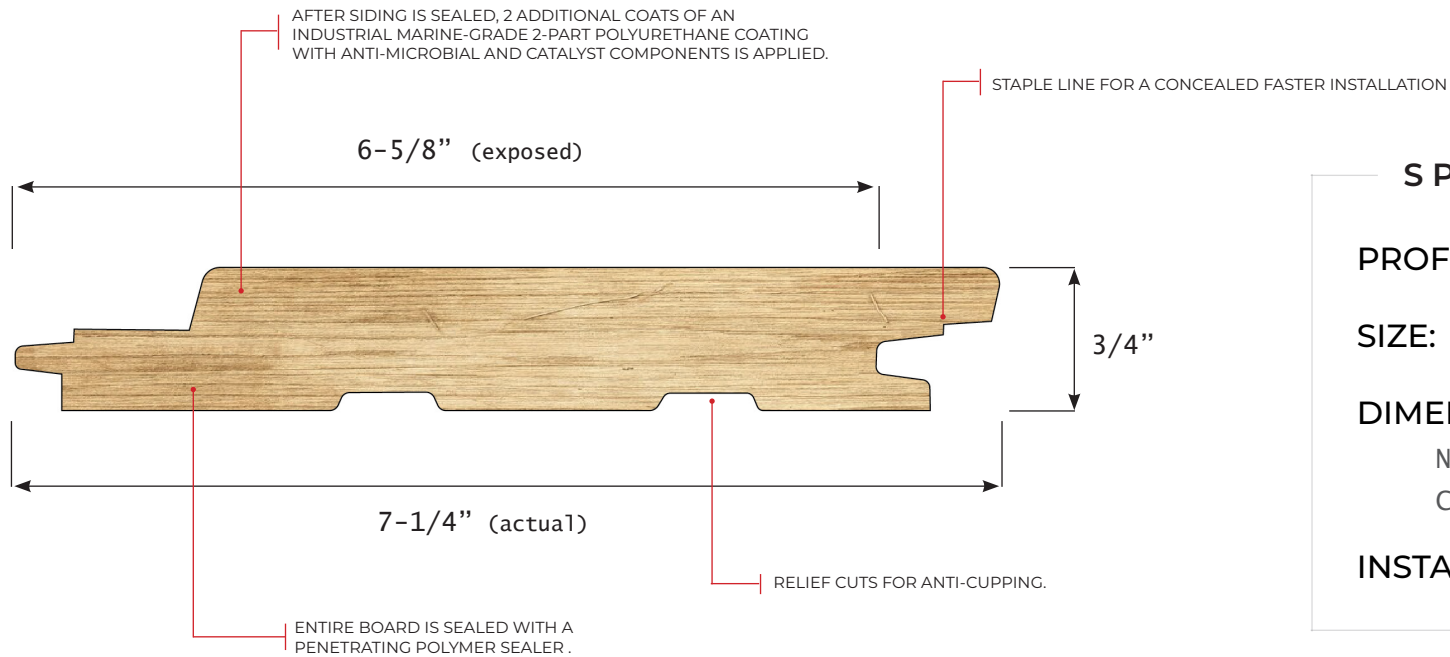

SPECIFICATIONS

PROFILE: EURO CHANNEL
* CUSTOM RUN PROFILE

SIZE: 8" Profile

DIMENSIONS:

Nominal: 3/4" x 7-1/4"

Coverage: 6-5/8"

INSTALL: Horizontal

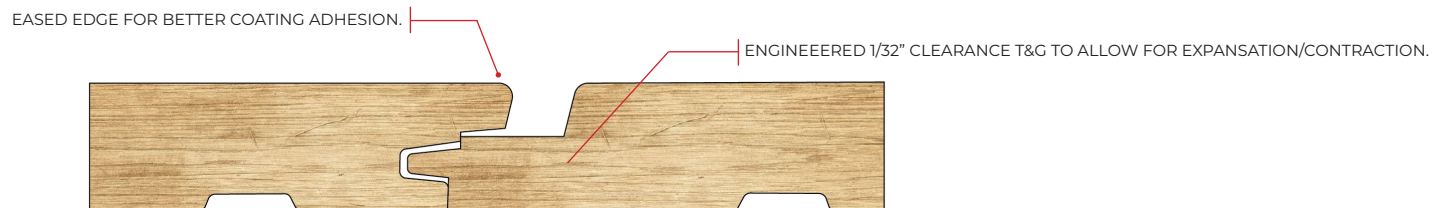

- WATERPROOF 2-PART POLYURETHANE COATING
- TONGUE & GROOVE FOR SEAMLESS DESIGN

- END-MATCHED FOR CLEAN TRANSITIONS
- STANDARD RESAWN OR WIRE BRUSH FINISH

- CUSTOM COLOUR MATCHING
- KILN-DRIED WHITE PINE



WOOD SIDING THAT LASTS A LIFETIME

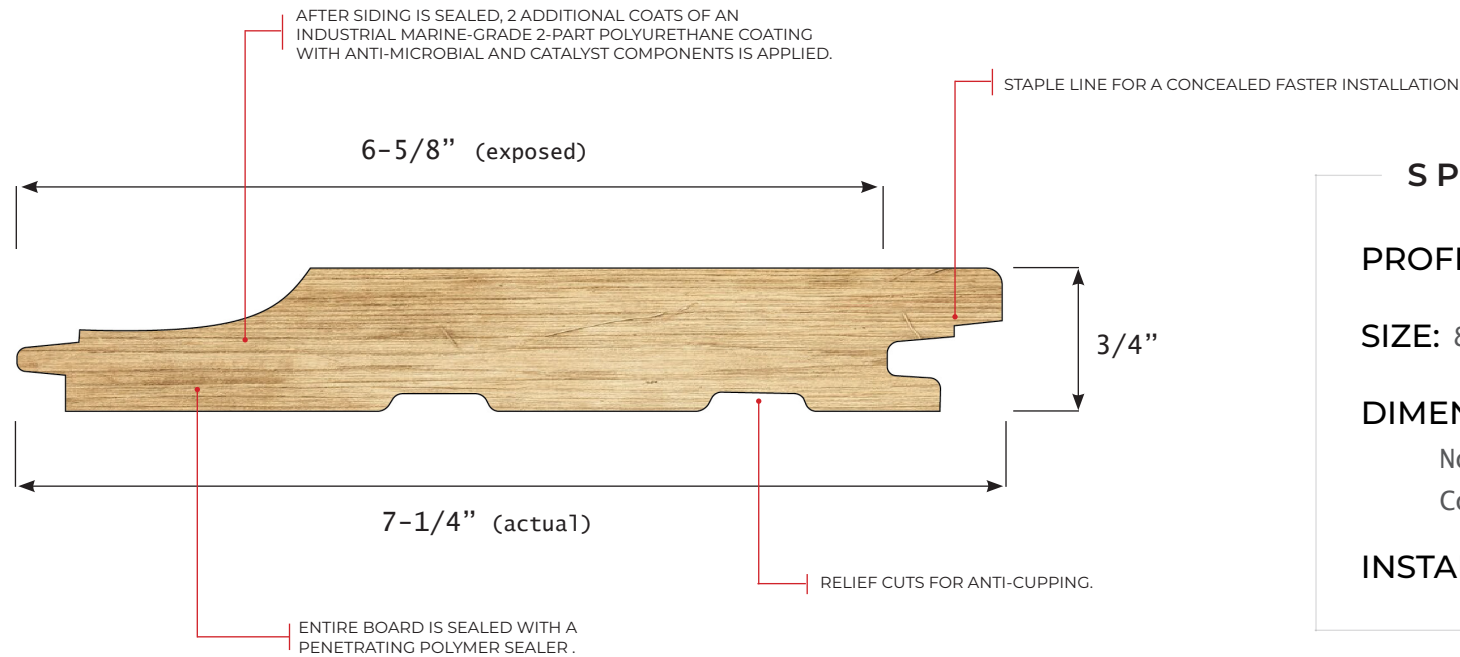

SPECIFICATIONS

PROFILE: COVE
* CUSTOM RUN PROFILE

SIZE: 8" Profile

DIMENSIONS:
Nominal: 3/4" x 7-1/4"
Coverage: 6-5/8"

INSTALL: Horizontal

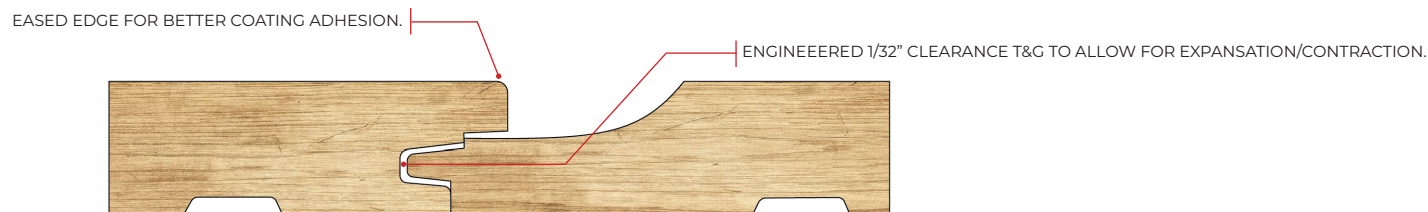

- WATERPROOF 2-PART POLYURETHANE COATING
- TONGUE & GROOVE FOR SEAMLESS DESIGN
- END-MATCHED FOR CLEAN TRANSITIONS
- STANDARD RESAWN OR WIRE BRUSH FINISH
- CUSTOM COLOUR MATCHING
- KILN-DRIED WHITE PINE



WOOD SIDING THAT LASTS A LIFETIME



AFTER SIDING IS SEALED, 2 ADDITIONAL COATS OF AN INDUSTRIAL MARINE-GRADE 2-PART POLYURETHANE COATING WITH ANTI-MICROBIAL AND CATALYST COMPONENTS IS APPLIED.

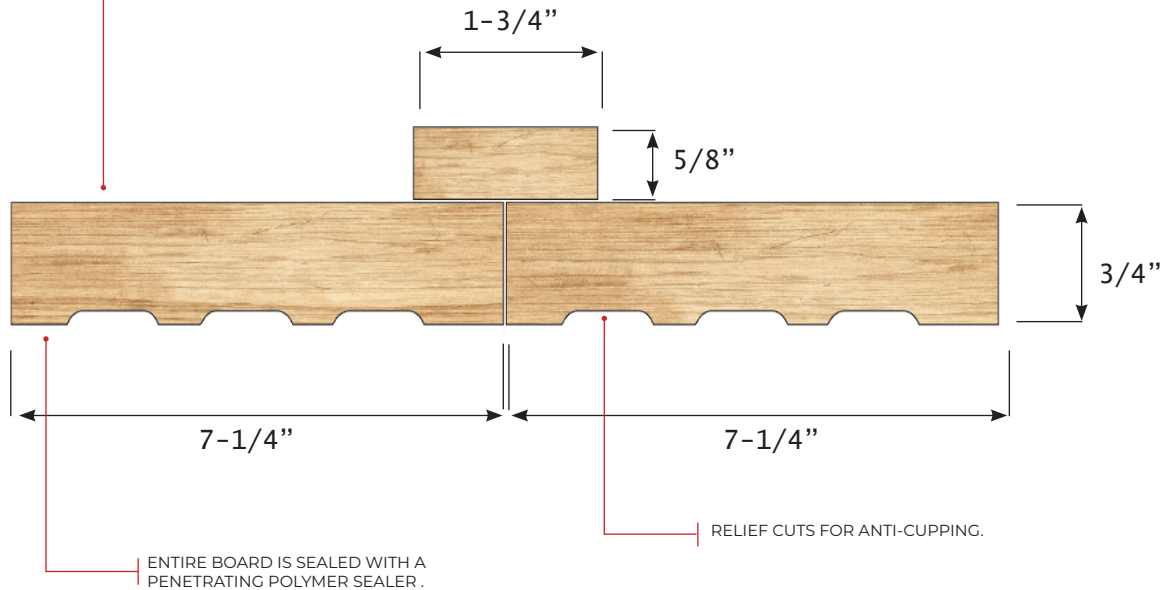

SPECIFICATIONS

PROFILE: BOARD & BATTEN
* CUSTOM RUN PROFILE

SIZE: 8" Profile

FINISH: Resawn or Wire Brushed

DIMENSIONS:

3/4" x 7-1/4" (BOARD)

5/8" x 1-3/4" (BATTEN)

INSTALL: Vertical



- WATERPROOF 2-PART POLYURETHANE COATING
- TONGUE & GROOVE FOR SEAMLESS DESIGN

- END-MATCHED FOR CLEAN TRANSITIONS
- STANDARD RESAWN OR WIRE BRUSH FINISH

- CUSTOM COLOUR MATCHING
- KILN-DRIED WHITE PINE



WOOD SIDING THAT LASTS A LIFETIME



AFTER SIDING IS SEALED, 2 ADDITIONAL COATS OF AN INDUSTRIAL MARINE-GRADE 2-PART POLYURETHANE COATING WITH ANTI-MICROBIAL AND CATALYST COMPONENTS IS APPLIED.

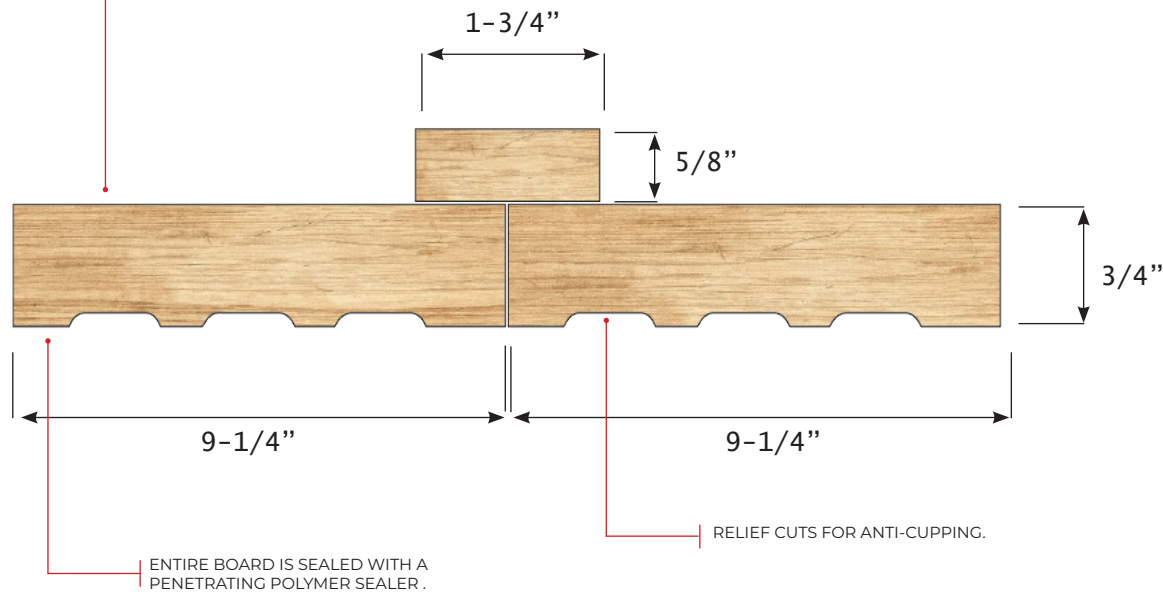

SPECIFICATIONS

PROFILE: BOARD & BATTEN
* CUSTOM RUN PROFILE

SIZE: 10" Profile

FINISH: Resawn or Wire Brushed

DIMENSIONS:

3/4" x 9-1/4" (BOARD)

5/8" x 1-3/4" (BATTEN)

INSTALL: Vertical



- WATERPROOF 2-PART POLYURETHANE COATING
- TONGUE & GROOVE FOR SEAMLESS DESIGN

- END-MATCHED FOR CLEAN TRANSITIONS
- STANDARD RESAWN OR WIRE BRUSH FINISH

- CUSTOM COLOUR MATCHING
- KILN-DRIED WHITE PINE